



PROJECT MARCH

Exoskeleton: Stand up and walk again

18/06/2019







The Exoskeleton





“Contribute to the mobility of people with a spinal cord injury.”

MARCH I



MARCH II



MARCH III



The Pilot

Health Advantages



Preview documentary “Sta op en Loop”

The emotional impact of standing up again



Design Process

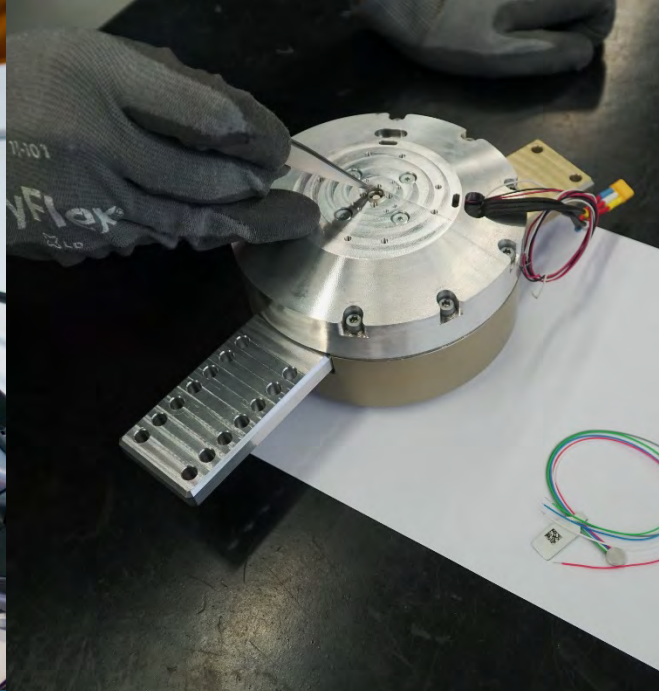



The Cybathlon



A person wearing dark blue jeans and white sneakers is walking on a large, weathered log in a forest. The ground is covered with fallen leaves, and the background is filled with green foliage and trees. The scene is captured from a low angle, focusing on the person's legs and the log.

Future vision



No crutches





All shapes and sizes



React Dynamically



Low-Profile

Human Machine Interaction



Bente



Karlijn

Input Device

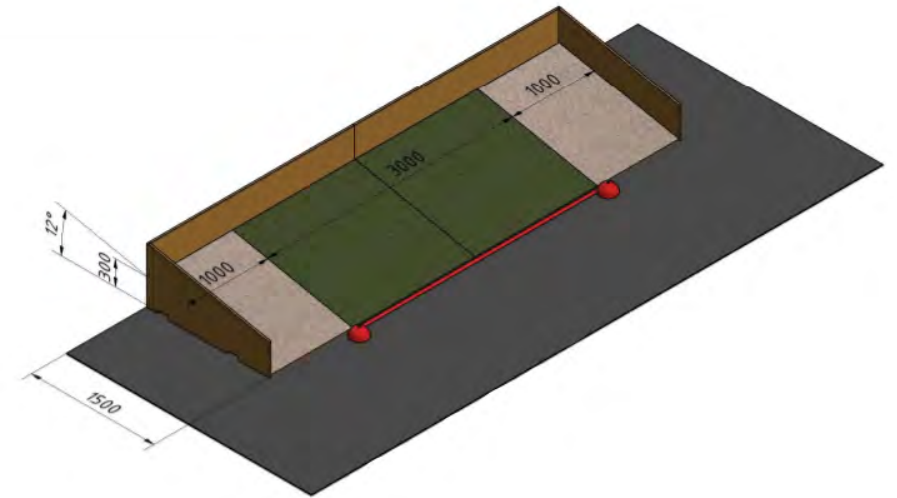
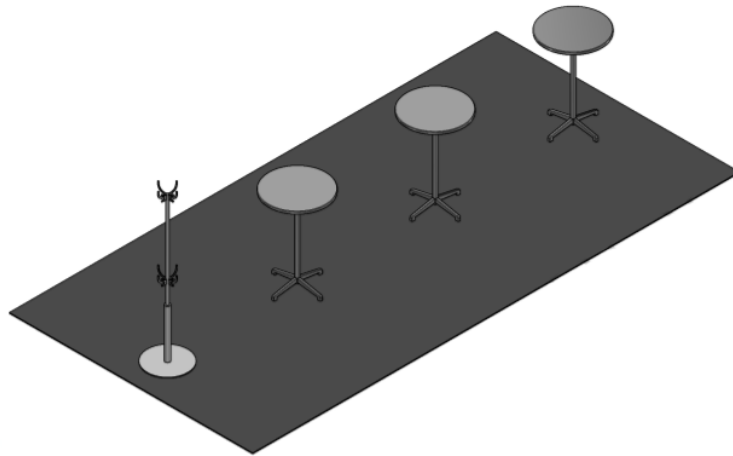
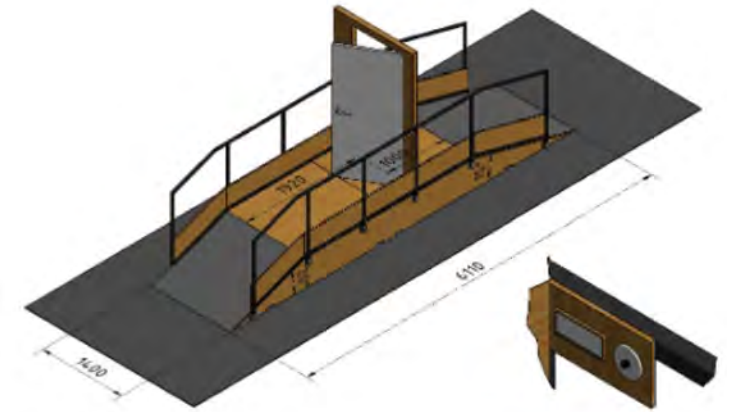
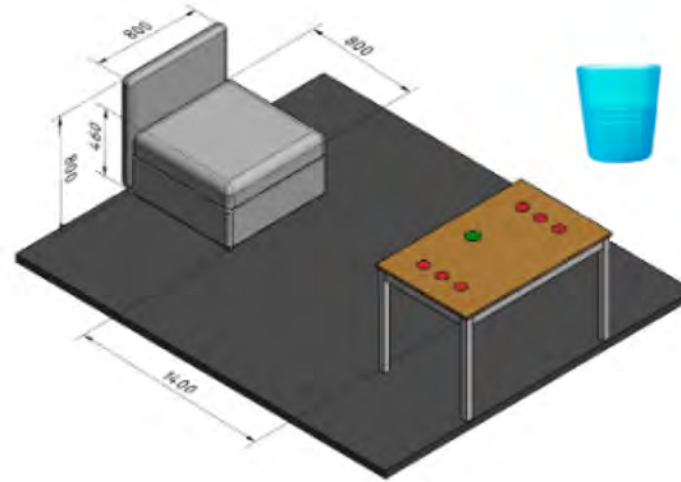
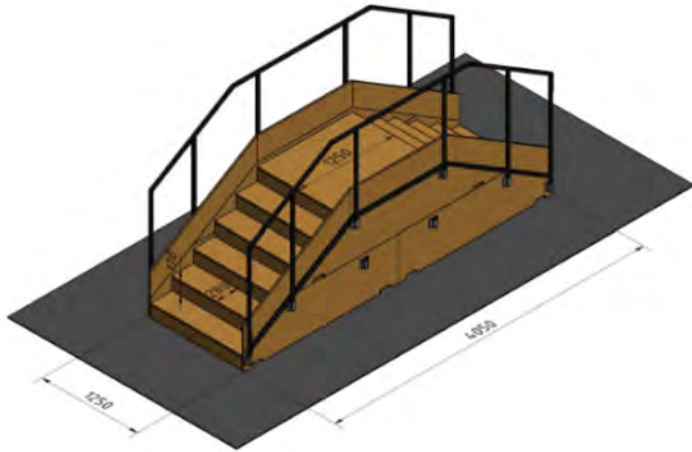

Conceptualization

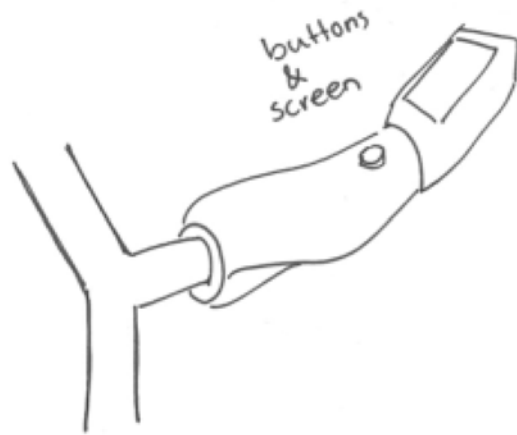

Concept 4

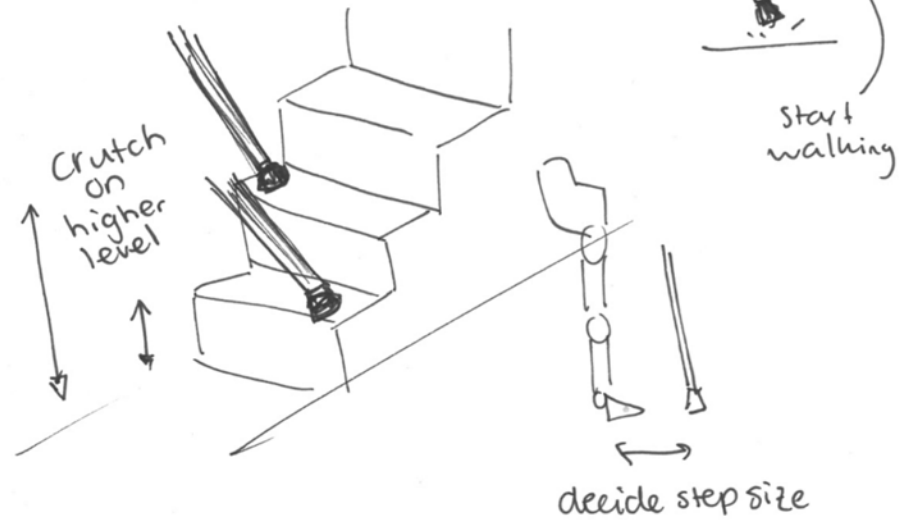

Concept 5

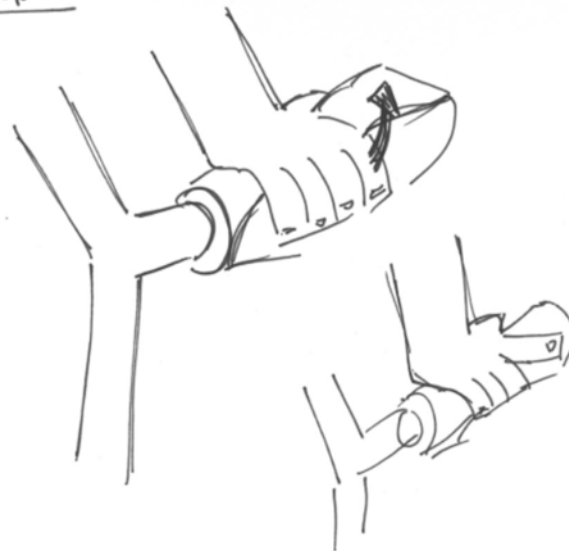

Concept 3

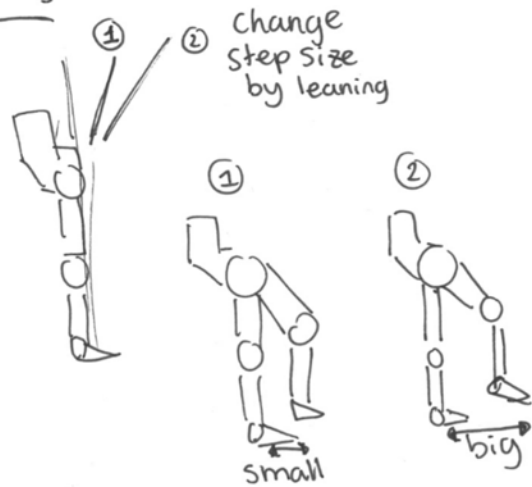



Shape Crutch Handle



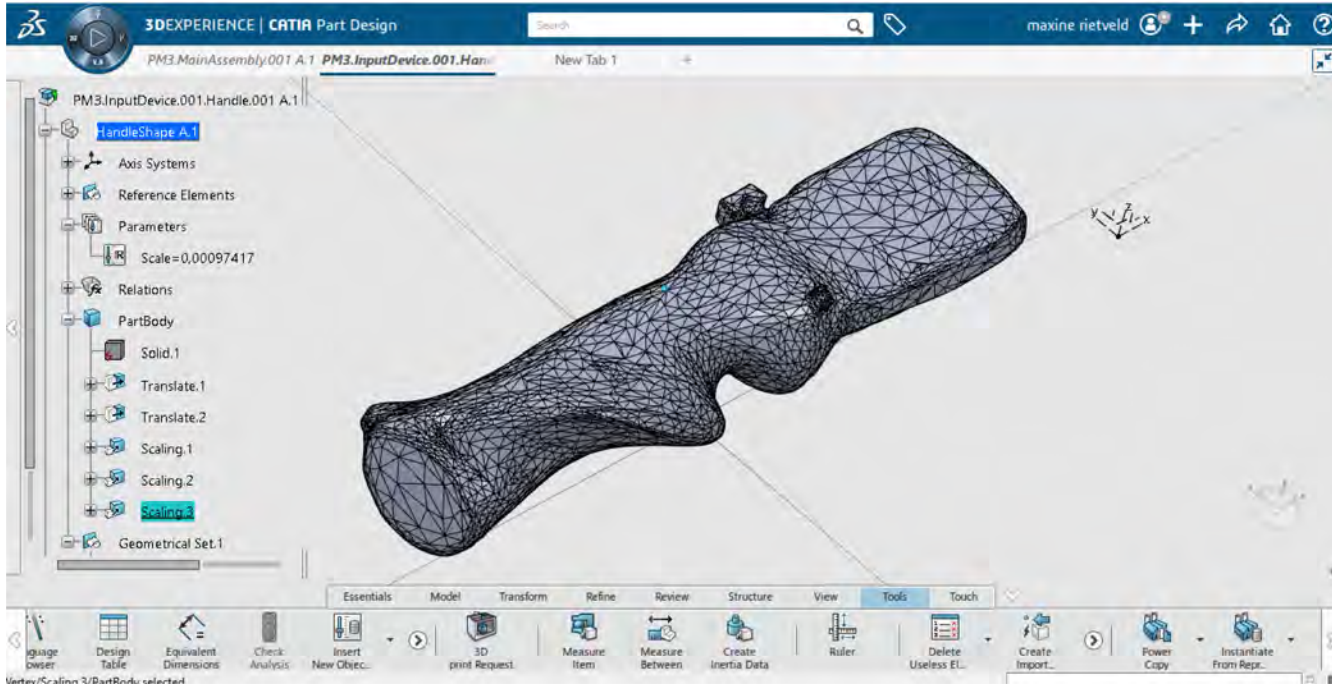

Embodiment

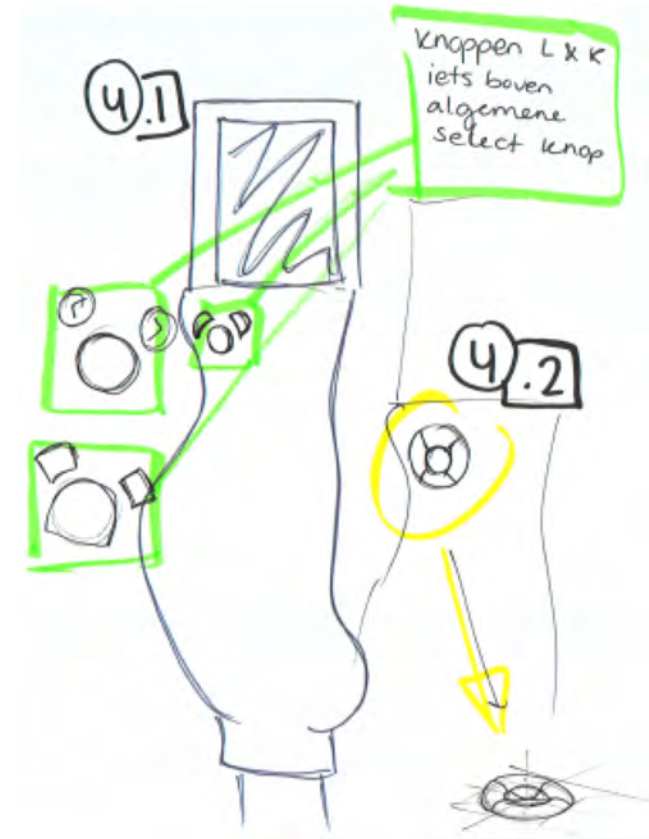
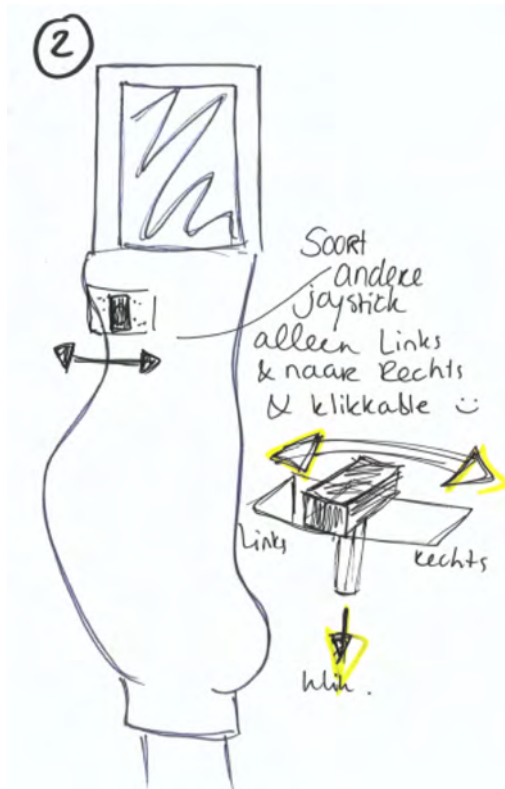
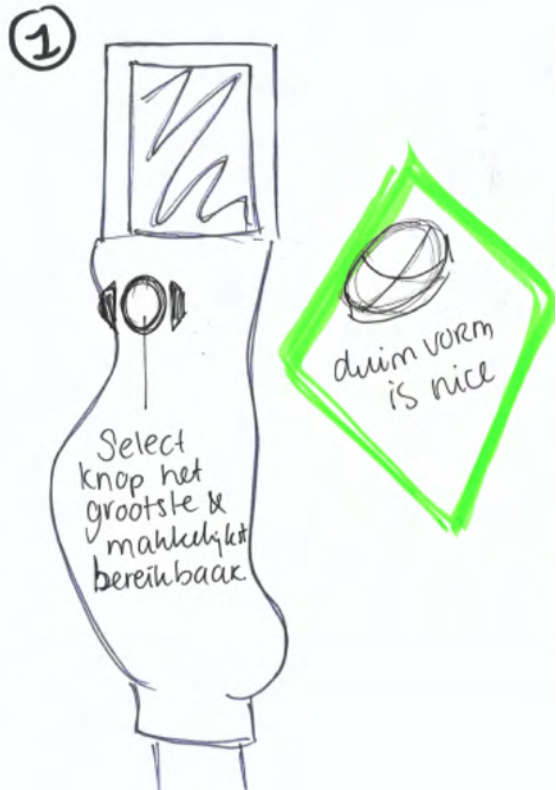

Testing

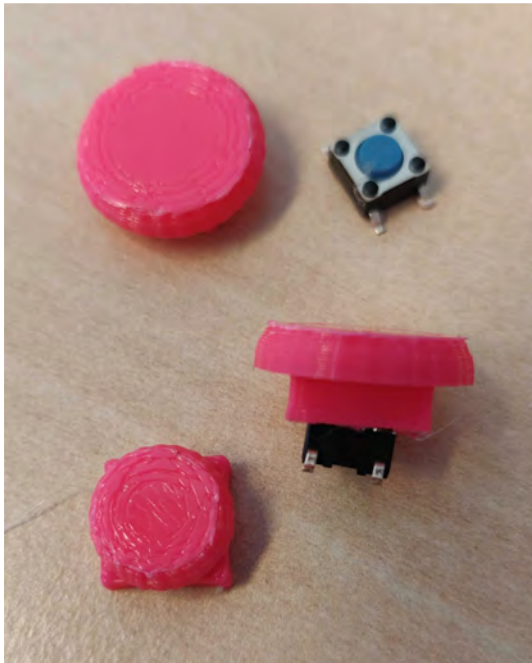

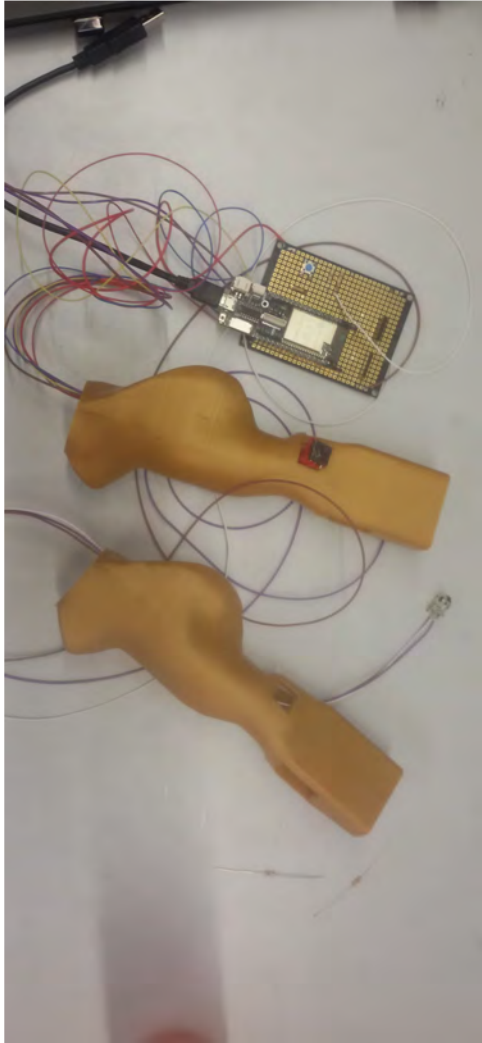

Detailed Design



Graphical user interface

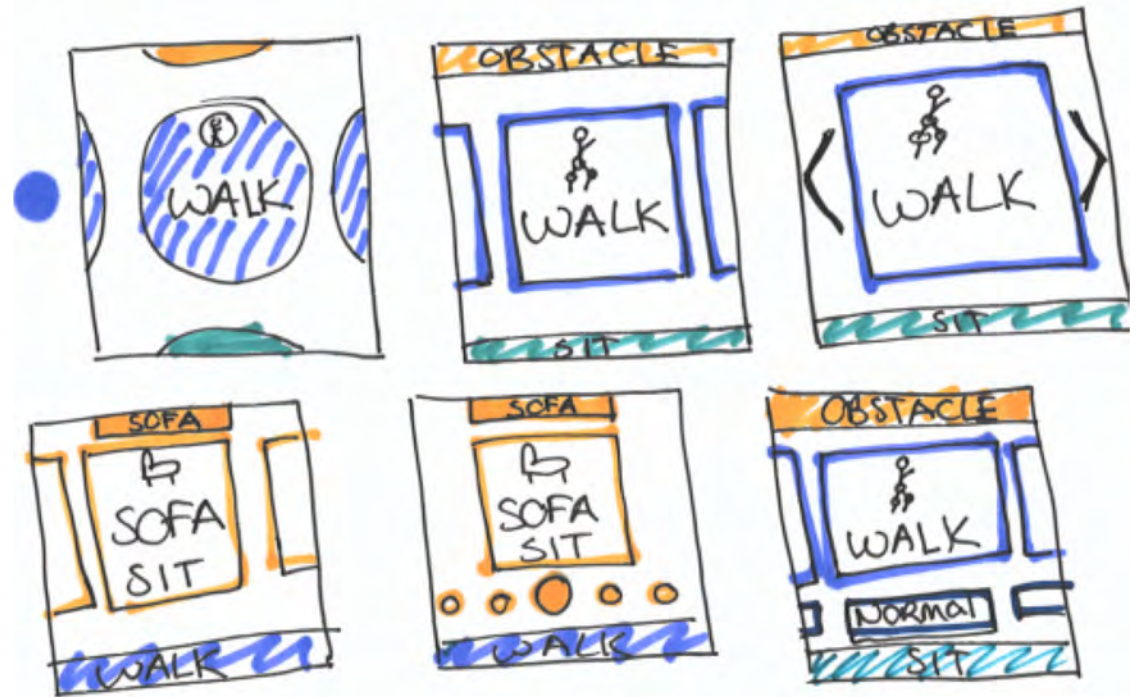
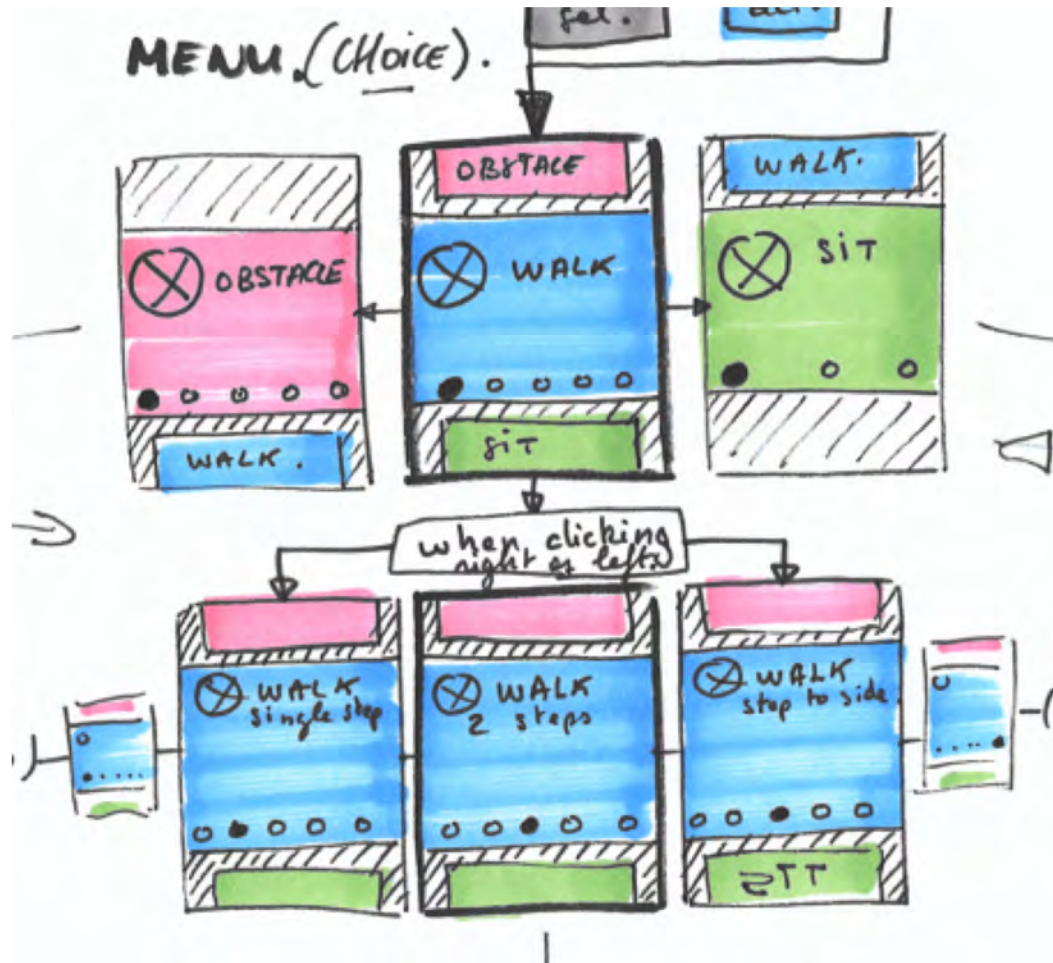

Graphical user interface

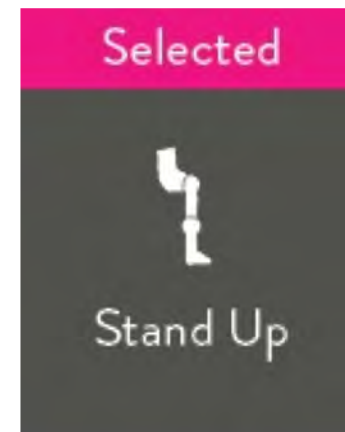
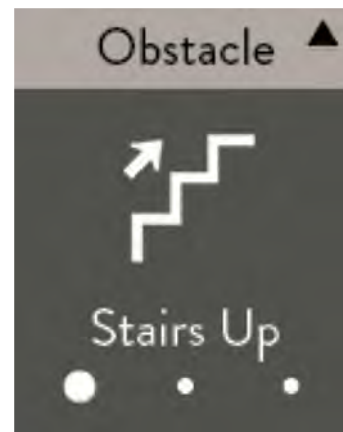
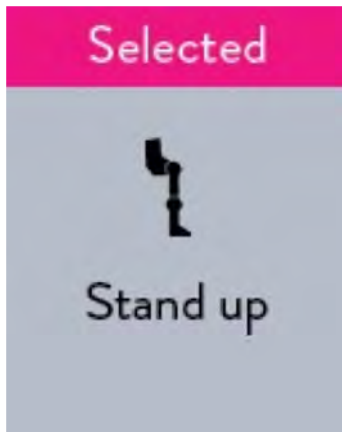
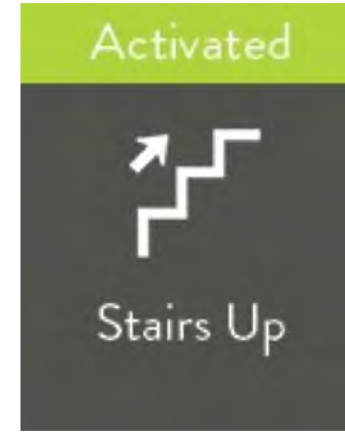
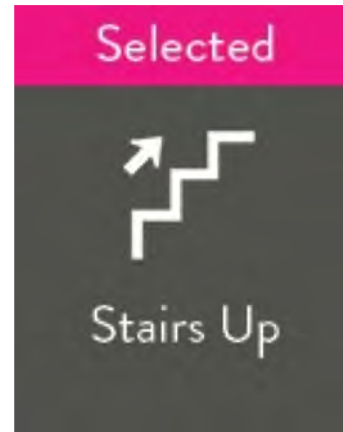
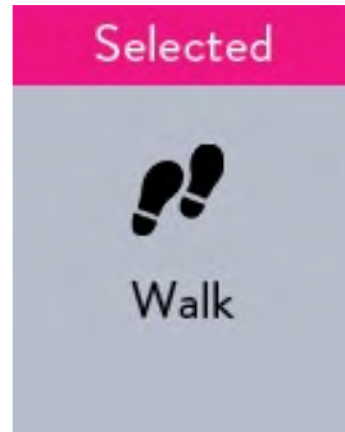

Selection scheme

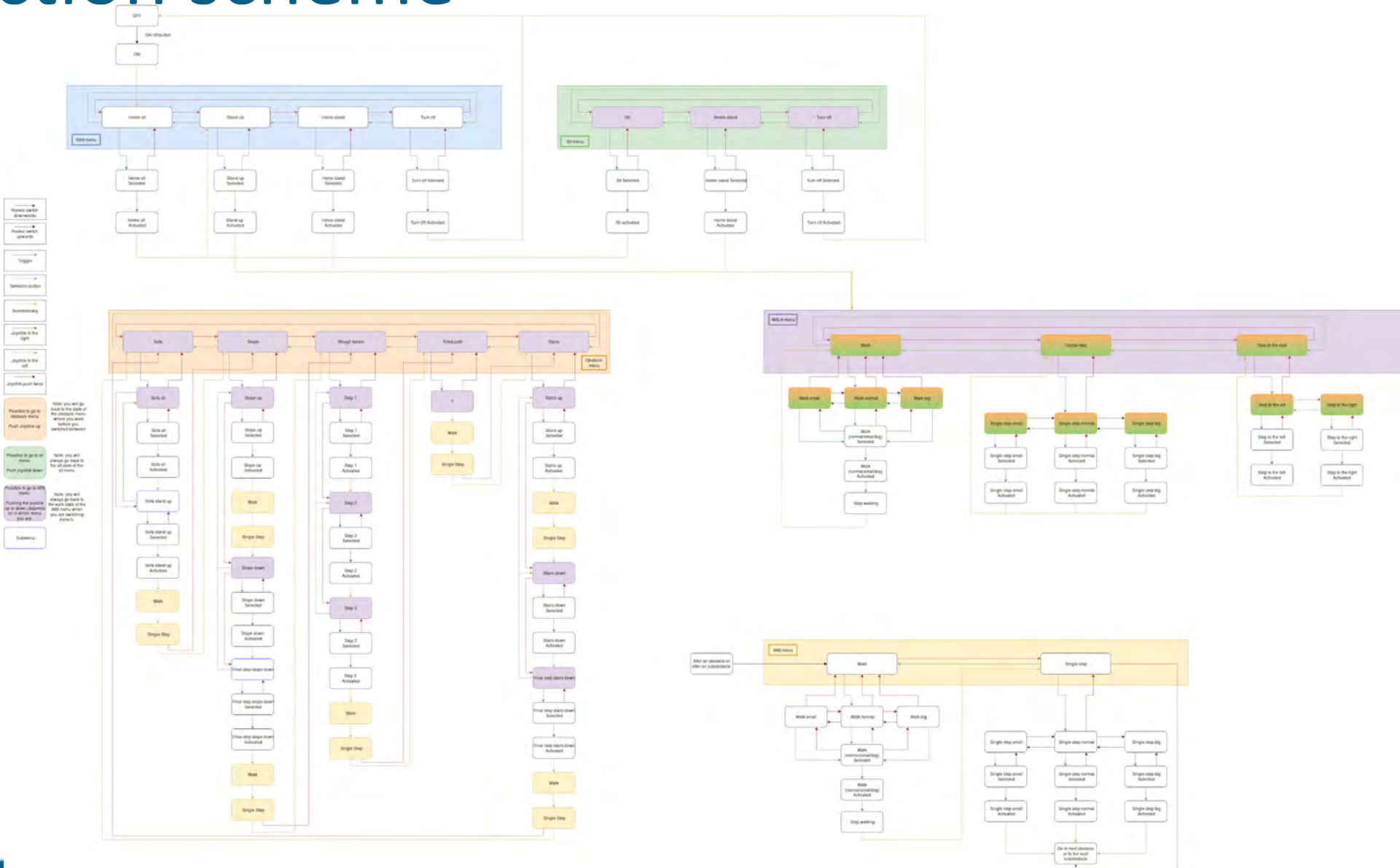

Feedback

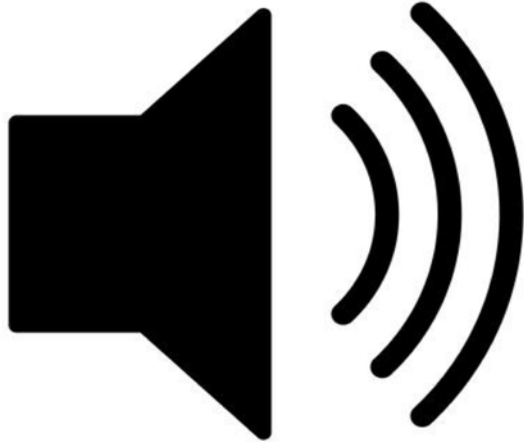
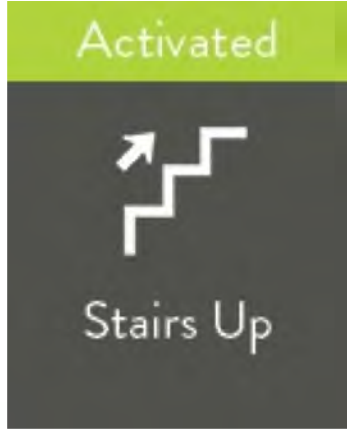

Assembly

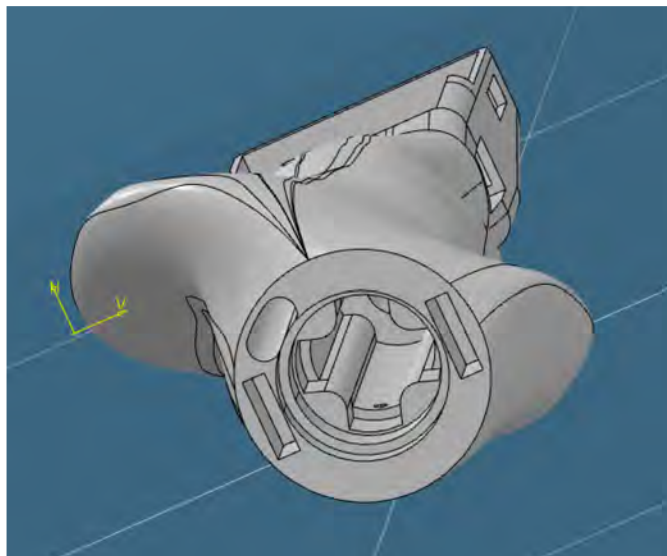
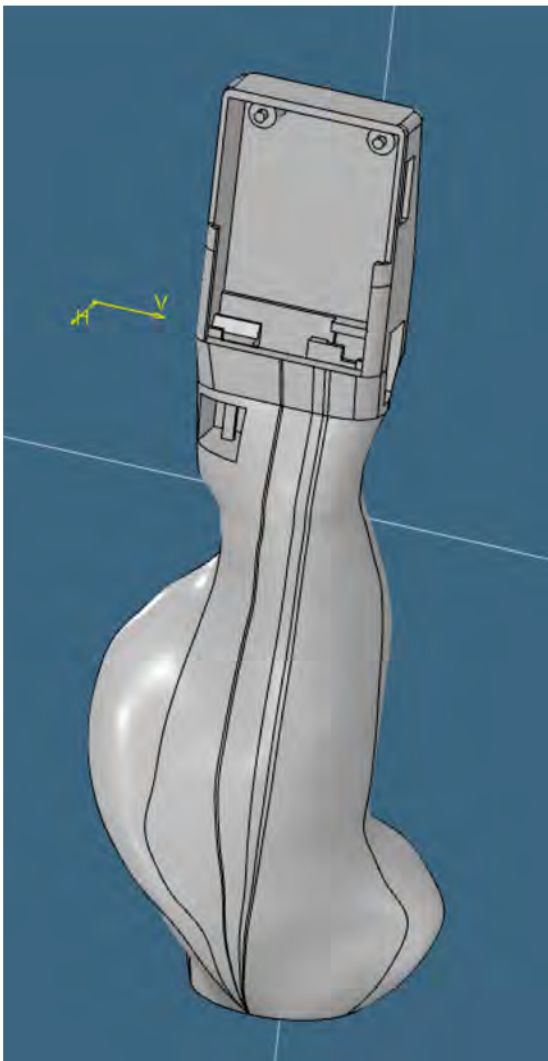

DIAMOND SPONSORS

DSW
zorgverzekeraar

PLATINUM SPONSORS

TU Delft



Sint Maartenskliniek

Agis
innovatiefonds

GOLD SPONSORS



SOURCE OF YOUR TECHNOLOGY



SILVER SPONSORS



Sintecs

RENISHAW

SKF



Frencken

EN SERIO

THE #1 PARTNER FOR
TECH INNOVATORS

BRONZE SPONSORS



THE SAFEST PROJECTION SYSTEM



Your 3D printing professional



www.demo.tudelft.nl



innovation
accelerators



DC POWER SUPPLIES



TRIDEUS



Harmonic
Drive AG



ProReva



SALOMON'S
WERF B.V.



PRODRIVE
TECHNOLOGIES



TU DELFT
SPORTS
ENGINEERING
INSTITUTE



BASF
Innofil



AGILEWERK



Jeveka



Altium



xsens

FRIENDS

rubbermagazijn.nl



Rosalie Putman



WÜRTH ELEKTRONIK



APT A



Djons



ottobock



Van Dierik



maxilia



Keonys



SMP KETELS



DISSAULT SYSTEMES



zemic



KINETIC BALANCE



ORTHOPEDIE
KESTELYN



WEST LAND

PROJECT MARCH